

P-50*i*B Paint Robot

***i*NTelligent SOLUTION**

FANUC ROBOTICS' P-50*i*B IS A HIGHLY FLEXIBLE AND ADVANCED SIX-AXIS PAINT ROBOT FOR A WIDE RANGE OF PAINTING APPLICATIONS. THE P-50*i*B IS ADAPTABLE IN ITS MOUNTING CONFIGURATIONS TO ACCOMMODATE THE MOST DEMANDING OF PAINT APPLICATIONS. OPTIONAL INNER-ARM TRANSDUCERS AND TRIGGER VALVES PROVIDE THE ABILITY TO MOUNT COMPONENTS CRUCIAL TO OVERALL PERFORMANCE AND PAINT QUALITY.

PROCESS ADVANTAGES:

- Ability to package process components in the outer arm in close proximity to the applicator for rapid, accurate, and consistent application performance
- Optional transducers and trigger valves are built into the inner arm for fast process control
- Flip-Over capability provides for a large work envelope
- Balanced arm design maximizes stroke length
- Two different arm lengths to choose from to optimize process requirements
 - 700mm inner arm & 700mm outer arm 15 kg payload - P-50*i*B/15
 - 900mm inner arm & 900mm outer arm 10 kg payload - P-50*i*B/10L
- R-30*i*A Mate Controller is compact and has the same powerful processor as larger robots
- Hollow wrist allows for compact and demanding process routing

SOFTWARE ADVANTAGES:

- Paint Application software provides the industry's most powerful and easy-to-use programming interface
- Dual Check Safety enables smaller booths and lower system costs
- Optional High Sensitivity Collision Detection protects robot and peripheral equipment
- Application software provides many choices of fluid delivery to meet demanding process control
- Process and production reporting along with diagnostic monitoring are all integrated into the software to maximize uptime
- Supports all major network communication protocols
- ROBOGUIDE PaintPro Offline 3D programming supported
- *i*Pendant color graphical teach pendant supported

FEATURES AND BENEFITS:

- Floor, wall, angle, and ceiling mount configurations
- Easily configured left hand or right hand arm to maintain symmetry across the booth
- Designed for ease of maintenance and easy access to all critical components
- High arm and wrist payload capacity support a variety of applications including rotary atomizers, conventional and electrostatic spray guns and multi-gun configurations
- Multiple mounting options for flexible spray booth integration
- Approved for use in hazardous locations; see specifications for details



P-50*i*B/15 shown with optional riser



P-50*i*B/10L shown with customer supplied riser

P-501B Paint Robot

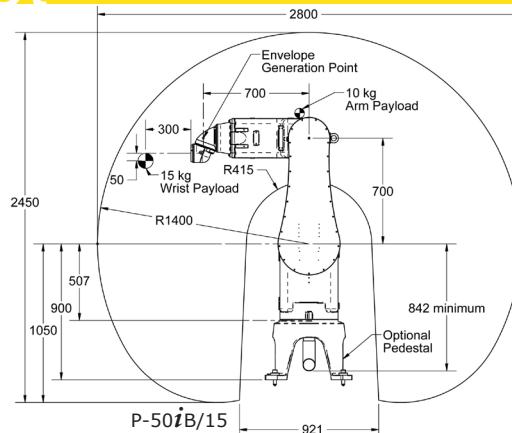
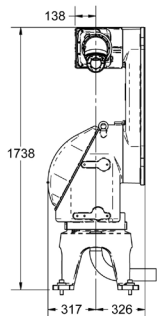
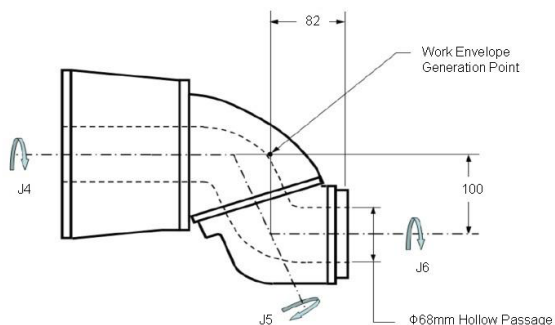

P-501B SPECIFICATIONS:

Item	Specification		Note	
	P-501B/15	P-501B/10L		
Controlled axes	6 axes robot			
Installation	floor, wall, angle, ceiling			
Reach	1400mm	1800mm		
Motion range & speed	J1	320°, 140°/s	320°, 140°/s	
	J2	240°, 140°/s	240°, 140°/s	
	J3	404°, 160°/s	404°, 160°/s	
	J4	1080°, 375°/s	1080°, 375°/s	
	J5	1080°, 430°/s	1080°, 430°/s	
	J6	1080°, 545°/s	1080°, 545°/s	
Payload capacity	Wrist/ (Outer - Inner Arm) @ 1500 mm/s	15kg/10kg	10kg/10kg	Wrist 300mm axial faceplate offset 50mm radial faceplate offset Total payload between inner and outer arm may not exceed specification
	Wrist/ (Outer - Inner Arm) @ 2000 mm/s	5kg/5kg	5kg/5kg	
Wrist moments N-m (kgf-m)	J4	65.02 (6.63)	43.35 (4.42)	
	J5	55.29 (5.64)	36.86 (3.76)	
	J6	7.36 (0.75)	4.90 (0.5)	
Wrist load inertia kg-m ²	J4	2.931	1.954	
	J5	2.119	1.413	
	J6	0.038	0.025	
Mechanical Brakes	All axes			
Drive Method/position Encoders	Electric servo drive AC servo motor/Absolute pulse encoders			
Repeatability	± 0.2 mm			
Robot weight	356kg	364kg	With optional base	
Installation Environment	0°C - 45°C			
Humidity	Normally: 75% or less Short term (within a month) 95% or less No condensation			
Vibration	0.5 or less m/s ² (G)			
Hazardous location certification (pending)	FMUC Class I, II, Div I, Group C, D, E, F, G, T4 45°C Ambient ATEX CE II 2 G c Ex ib px IIB T4 Ta=0°C to +45°C ATEX CE II 2 D c Ex pD 21 T 135°C Ta=0°C to +45°C Note: iPendant for unclassified areas only			

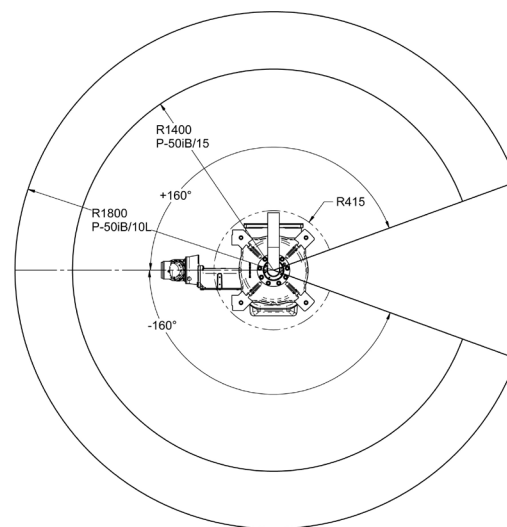
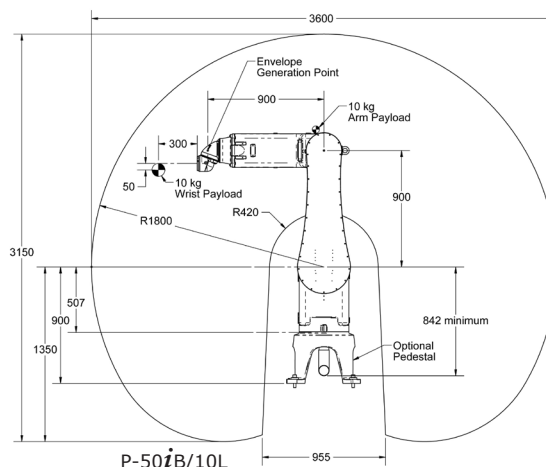

* Work envelope generated with point identified in figure 1.

Reach measured to wrist faceplate is 82mm larger.



FANUC ROBOTICS AMERICA CORPORATION
3900 WEST HAMLIN ROAD
ROCHESTER HILLS MI 48309-3253

